

ASSEMBLY INSTRUCTION

CRASH PAD KIT KTM DUKE 790 '18

KTM 7101-18

WWW.BARRACUDAMOTO.COM

KIT

X2. PAD HEAD
X2. BASE PAD
X2. SPECIFIC THICKNESS
X2. M10X140 ALLEN SCREW

ASSEMBLY PROCEDURE:

1. UNSCREW THE BOLTS HIGHLIGHTED IN THE ILLUSTRATION THAT FIX THE ENGINE TO THE FRAME.
2. ASSEMBLE THE RIGHT AND LEFT PAD KIT, ASSEMBLING IT AS SHOWN.
3. TIGHTEN THE M10X140 ALLEN SCREW AND SCREW THE HEAD PADS.

LEFT

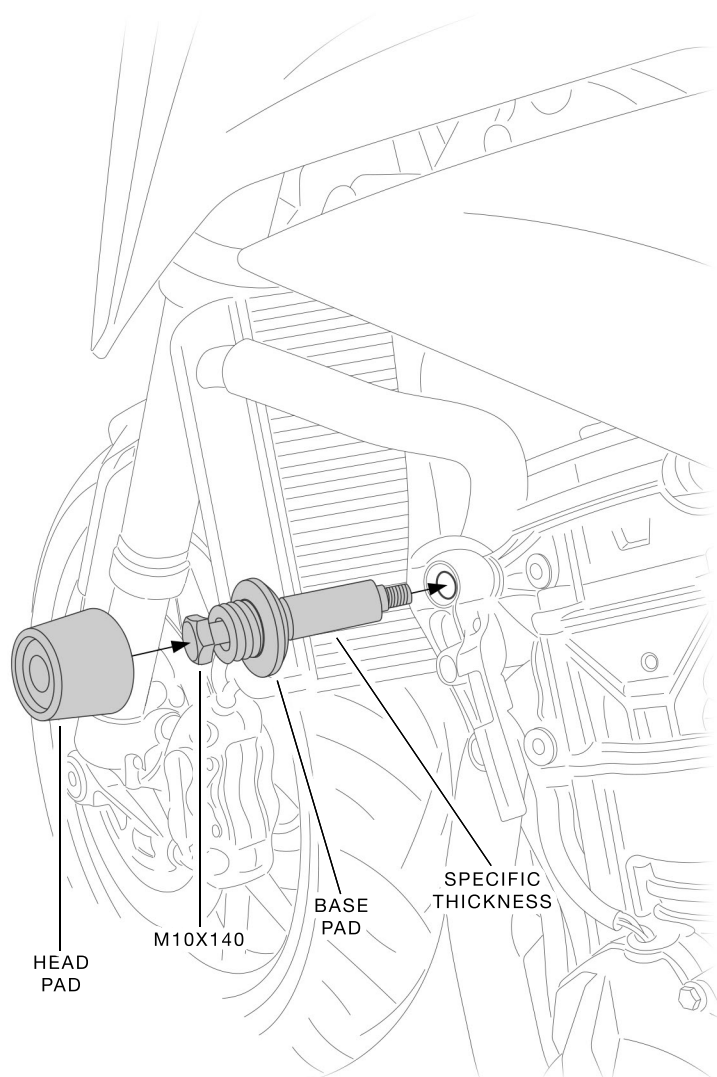

RIGHT

